

Power over Ethernet - the reality of designing a Powered Device

There have been many technical articles, white papers and product application notes that explain the theory on how to make a powered device. They give an overview of the IEEE 802.3af standard for Power over Ethernet and explain how to extract the power from the CAT5e cable. The following is a practical guide to help take that information and to design a PoE enabled powered device.

By Tony Morgan, Silver Telecom Ltd

The Powered Device (PD) can be broken down into four basic building blocks as shown in Figure 1.

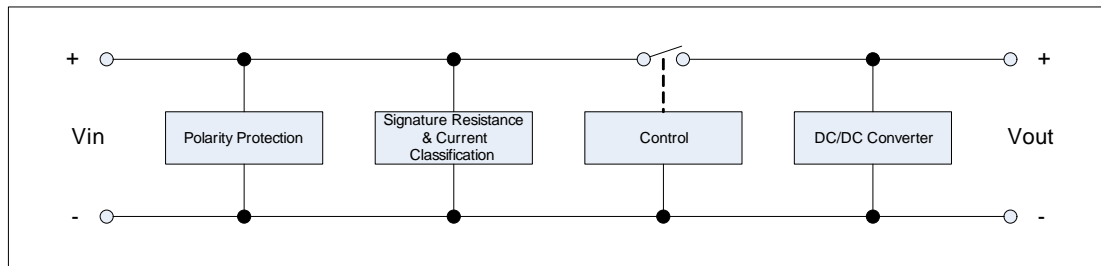

Figure 1: Building Blocks of a Powered Device (PD)

The first block is “Polarity Protection” or “Auto-polarity Circuit”. This is required as the IEEE specification allows the power to be injected onto the Cat5e cable in a number of ways. “Alternative A” shown in Figure 2, injects and extracts the power using the centre tap of the data transformers (Medium Dependant Interface or MDI). The PSE can apply the positive to the centre tap of the TX pair transformer or the RX pair transformer (or a crossover cable could be used). Therefore the PD must be able to handle the unknown polarity and operate normally. A simple bridge rectifier will do the job and the IEEE specification allows for such a component to be used in the PD’s input.

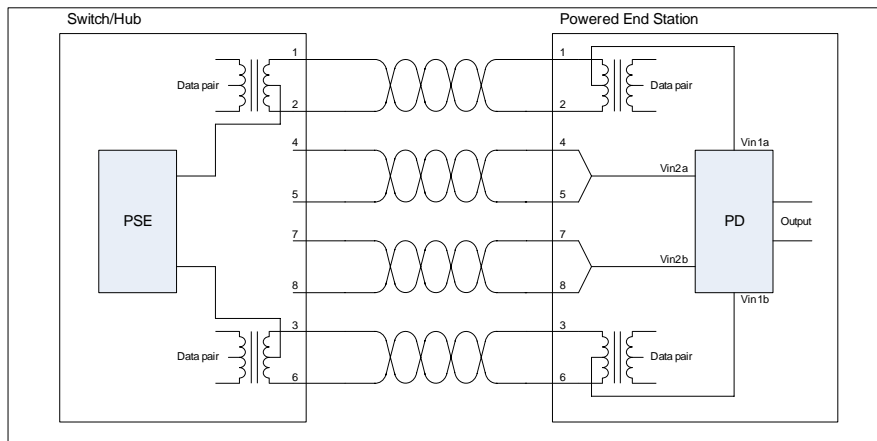

Figure 2: Endpoint PSE, Alternate A

The other alternative methods detailed in the IEEE specification are shown in Figure 3 and Figure 4. Where the power is supplied by the PSE over the Power Interface (PI), or the spare pairs in 10BASE-T and 100BASE-T networks.

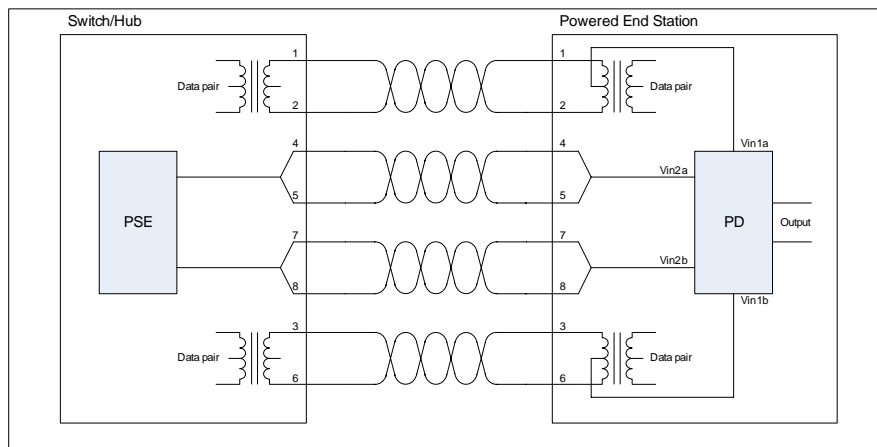

Figure 3: Endpoint PSE, Alternate B

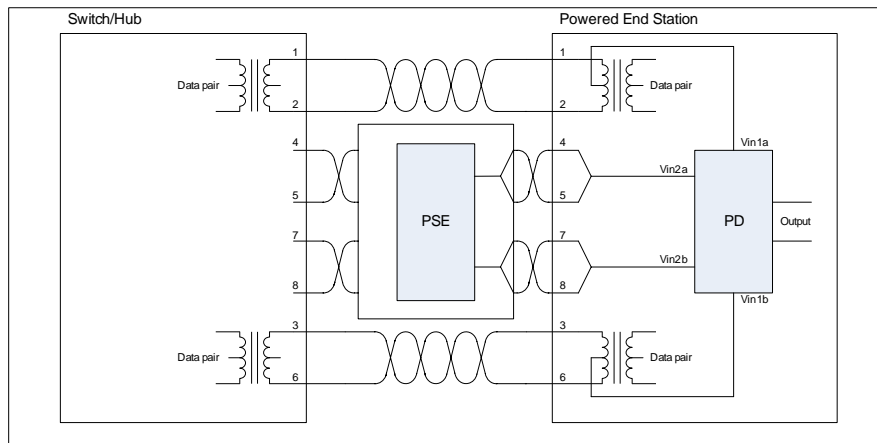

Figure 4: Midspan PSE, Alternate B

In Figure 3 and Figure 4 the IEEE specification states that the PSE positive must be connected to 4 & 5 and the negative connected to 7 & 8. So if the polarity is fixed does the Vin2 input to the PD require a bridge rectifier? It doesn't need a full bridge rectifier but it would be worth putting two diodes in-line to match the way the Signature circuit responds to either input method.

The IEEE specification details 10BASE-T and 100BASE-T networks, but only makes references to 1000BASE-T networks. 1000BASE-T network topology differs from 10BASE-T and 100BASE-T networks in that it uses all four pairs within the cable to transfer data. If a powered device using one of the methods shown above is connected to a 1000BASE-T network, then two of the data pairs will be shorted. Figure 5 shows how to configure the PD to work with a 1000BASE-T network.

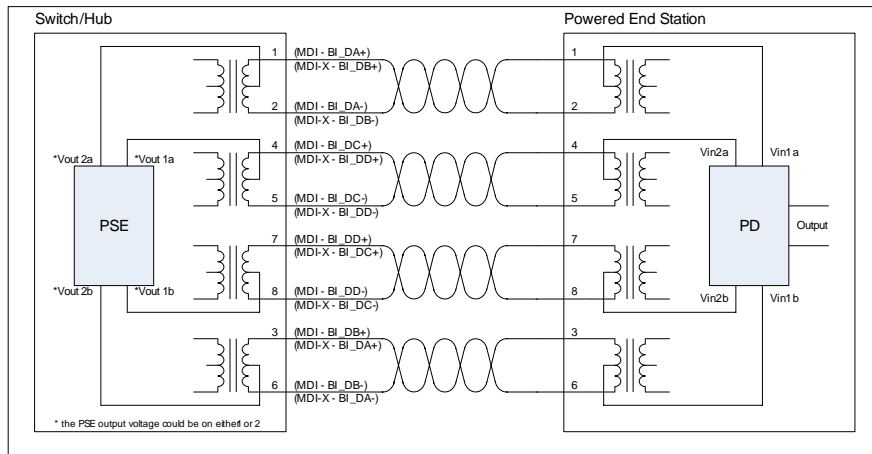

Figure 5: 1000BASE-T Configuration

The second building block is the Signature and Class circuitry. To ensure that the PSE does not apply 48V to a non POE enabled device, the PSE will initially apply a low voltage (2.7V to 10.1V) and look for a Signature Resistance of 25K Ohms. The PSE will expect that the Signature Resistance will be after some form of Auto-polarity Circuit and will compensate for the DC offset in the Signature. The maximum input capacitance of the PD must be <150nF. There are a number of PSE's that don't check this parameter, but some do. It is important to remember that if the Signature Resistance is not switched out when the full PSE voltage is applied, it will need to dissipate ~130mW (25K @ 57V).

The "Current Classification" or "Class Circuitry" is used to inform the PSE of the maximum power used by the PD. This is useful for power management in larger switch/hubs. After a valid Signature the PSE will increase it output voltage between 14.5V and 20.5V and measure the current. Table 1 shows the different Class ranges available, this is optional and providing the measure current is <=4mA the PSE will default to Class 0. Class 4 has been reserved and may be used in the future.

Class	Measured Current (mA)	PD Power Max (W)	Comment
0	0 to 4	0.44 to 12.95	Default
1	9 to 12	0.44 to 3.84	Optional
2	17 to 20	3.84 to 6.49	Optional
3	26 to 30	6.49 to 12.95	Optional
4	36 to 44	Reserved	Not Allowed

Table 1: PD Power Classification

The third building block is the under-voltage lock-out or control stage. It is important that the DC/DC converter does not operate when the PSE is validating the Signature and Current Classification. The control stage must be ON when the PD input voltage = 35V, the PSE output voltage (Von) = 42V with 20 Ohms series resistance (cabling and connectors) at 350mA.

The IEEE specification does contradict itself with the Voff voltage. It states that control must be OFF if the PSE output voltage = 30V with 20 Ohms series resistance, implying that it can go down to 23V. But in the recommended PD power supply test procedure the specification states that the input current must be <1.14mA at 30V. So to ensure that the PD complies with the specification set the control switch threshold between 30V to 35V.

The forth and final building block is the DC/DC converter. A nominal 48V is not the most practical voltage and most applications would require a lower voltage such as 3.3V, 5V or 12V. An effective way of achieving this would be to use a DC/DC (Buck) converter. This converter must be capable of operating normally over a wide input range 36V to 57V, under minimum to maximum load conditions.

A question often asked is “How much power is available?” The PSE will be capable of outputting 15.4W (350mA @ 44V). But the IEEE 802.3af specification states that with 20 Ohms series resistance, the maximum input power to the PD = 12.95W (350mA @ 37V). If the DC/DC converter is 80% efficient then the available output power = 10.36W. This is something to be aware of this when working out the actual power, under worse case conditions. The IEEE have set-up a new task force to progress POE further with a higher power standard IEEE 802.3at. This is still in progress and the new standard is not expected to be ratified in the near future.

Linked to the maximum available power will be heat. It is important to remember that even the most efficient DC/DC converters will generate heat and this must be taking into account at the design stage. Ensure that the enclosure is ventilated and the DC/DC has sufficient heatsinking, failure to do this may result in a reduced power budget.

Another important consideration when designing the DC/DC converter stage is Electromagnetic Interference (EMI) and the PCB layout will affect this. Here are a few guidelines to reducing noise:-

- 1: Position the power components close together, to minimise power loops.
- 2: Keep tracks with high dv/dt as small as possible, to minimise radiation.
- 3: Keep high impedance tracks away from those with high dv/dt.
- 4: Keep the track to the FET gate as short as possible.
- 5: Maximise the copper on power and ground track.

Another question that is frequently asked is “Does the PD need 1500V isolation?” The IEEE specification states that “electrical isolation shall be in accordance with the isolation requirements between SELV circuits and telecommunication network connections in subclause 6.2 of IEC 60950-1:2001”, so the answer to the question is “Yes”. There are two approaches that can be used which will depend on the final product. Either the DC/DC converter could have the isolation barrier built-in, or if the product completely enclosed in a non-conductive material that could form the isolation barrier.

Power over Ethernet offers many benefits and can be used in a wide range of applications. There are modular and silicon solutions available today which are designed specifically for the powered device and under the existing specification IEEE 802.3af these can provide ~12W. Several PSE manufacturers have developed equipment that offers high power, but they have not standardised on their approach and at this point in time the IEEE 802.3at standard is still a work in progress.

About the author:

Tony Morgan is Senior Applications Engineer with Silver Telecom. Having worked at Mitel Semiconductor (Zarlink) and TT Electronics, Tony has been with Silver Telecom since January 2004. Silver Telecom is a leading developer of telephone interface, and power over ethernet solutions. Established in 1997, the company provides solutions for developers of the latest ethernet and telecommunications equipment, particularly within the growing areas of VoIP and computer telephony. The company continues to invest heavily in product development, releasing innovative products specifically in their SLIC, DAA and PoE (powered device) ranges with specific attention to low cost, small size and ease-of-use. Silver Telecom is privately owned with headquarters in Newport, Wales, and an extensive sales network covering 6 continents.

For further information please contact

Tony Morgan
Silver Telecom Ltd

T: +44- 1633 811833
F: +44 1633 811834
e: sales@silvertel.com
w: www.silvertel.com